

FEATURES:

- RUGGED ALL METAL CONSTRUCTION
- UNEQUALLED TEMP. RANGE: -200°F TO 500°F
- THREE AXIS CAPABILITY
- MAINTENANCE FREE
- FAIL SAFE DESIGN
- HIGH DAMPING: C/Cc ≈ .20
- EXCEPTIONAL RELIABILITY AND LONG LIFE

MATERIALS/FINISHES:

- CABLE: 300 SERIES SS PER MIL-W-83420 OR RR-W-410
- SCREWS: 300 SERIES SS PER MS51959-42
- INSERTS: 300 SERIES SS (ALUM BARS ONLY)
- RETAINER BARS: SEE BELOW

PART NUMBER	DIMENSIONS, in.		ISOLATOR WEIGHT (SEE NOTE 3)
	H ±.03	W (REF)	
SB4 - 110 - 04 - []	1.10 (27,9)	1.40 (35,6)	.13lbs (.06kg)
SB4 - 120 - 04 - []	1.20 (30,5)	1.50 (38,1)	.13lbs (.06kg)
SB4 - 130 - 04 - []	1.30 (33,0)	1.60 (40,6)	.14lbs (.07kg)
SB4 - 140 - 04 - []	1.40 (35,6)	1.70 (43,2)	.15lbs (.07kg)
SB4 - 150 - 04 - []	1.50 (38,1)	1.80 (45,7)	.15lbs (.07kg)
SB4 - 160 - 04 - []	1.60 (40,6)	1.90 (48,2)	.16lbs (.08kg)

MOUNTING HOLE OPTIONS

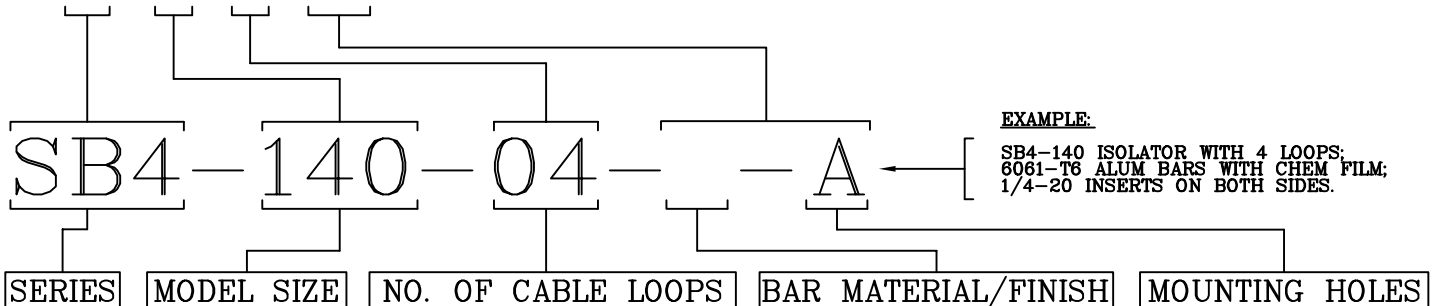
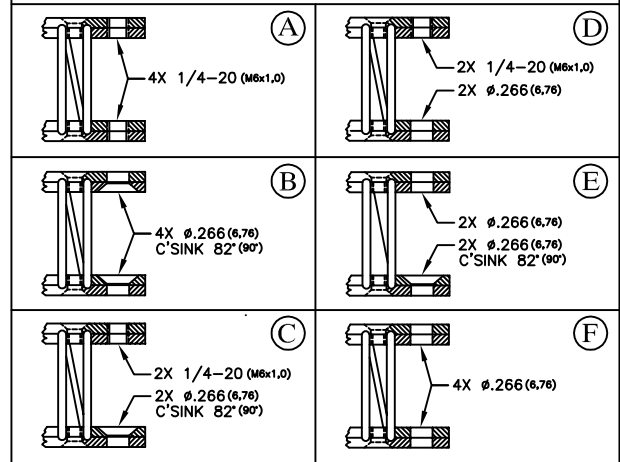

SERIES	MODEL SIZE	NO. OF CABLE LOOPS	BAR MATERIAL/FINISH	MOUNTING HOLES
• CABLE DIAMETER IN 32NDS	• BASED ON ISOLATOR HEIGHT	• 4 LOOPS STANDARD FOR THE SB4 SERIES. • ISOLATOR SPRING RATES ARE DIRECTLY PROPORTIONAL TO NO. OF CABLE LOOPS.	• [] = 6061-T6 ALUM ALLOY/CHEM FILM IAW MIL-DTL-5541, TYPE II, CL 3. • [H] = 6061-T6 ALUM ALLOY/ANODIZED IAW MIL-A-8625, TYPE II CLASS 1. • [S] = 300 SERIES SS/PASSIVATED IAW QQ-P-35C, TYPE II.	• SEE MOUNTING HOLE OPTIONS ABOVE. • ADD 'M' TO END OF P/N FOR METRIC MOUNTING HOLES. • ADD 'L' TO END OF P/N FOR LOCKING INSERTS.

NOTES:

- 1) ALL DIMENSIONS IN PARENTHESIS ARE METRIC (mm).
- 2) SPECIALS AVAILABLE UPON REQUEST (MATERIALS, SIZE, MOUNTING HOLES, FINISH, ETC...)
- 3) ADD .13lbs (.06kg) TO ISOLATOR WEIGHT FOR ALL-STAINLESS STEEL VERSIONS.

TOLL FREE : 888-ISOLATOR
FAX : (631) 491-5672
WEB SITE : www.isolator.com
E-MAIL : sales@isolator.com
CAGE : 07QQ7

